

*Braeburn*®

 *Robertshaw*

The brighter choice®



**Wall Thermostats and  
Zoning Systems**

## Thermostats

### Thermostats

#### Builder Series

500 / 505 <b>meGaswitch</b> ® Mechanical.....	3
1000NC / 1200NC Non-Programmable.....	3
2000NC / 2200NC Programmable .....	3
1020NC / 1025NC / 1220NC Non-Programmable.....	4
2020NC / 2220NC Programmable .....	4

#### Economy Series

1020 / 1220 Non-Programmable.....	5
2020 / 2220 Programmable .....	5

#### Premier Series

3020 / 3220 Non-Programmable .....	6
5020 / 5220 Programmable .....	6

#### Premier Series Touchscreen

5310 / 5320 .....	7
-------------------	---

#### Deluxe Series Touchscreen

6100 / 6300 / 6400 .....	8
--------------------------	---

#### BlueLink® Wi-Fi

7205 / 7300 / 7305 / 7320 .....	9
BlueLink Smart Connect® App.....	10

#### BlueLink® Wireless

7500 .....	11
------------	----

Thermostat Accessories .....	13
------------------------------	----

FREE Contractor Branding .....	14
--------------------------------	----

Thermostat Feature Comparison .....	24
-------------------------------------	----



## Zoning Systems



### Zone Control Panels

#### Economy Series

140202 2-Zone Control Panel .....	15
140303 3-Zone Control Panel .....	15

#### Premier Series

140221 2-Zone Control Panel .....	17
140332 3-Zone Control Panel .....	17
140404 Expandable 4-Zone Control Panel .....	19
140424 2-Zone Expander Control Panel .....	19

### Zone Control Dampers

Round Zone Dampers.....	21
Rectangular Zone Dampers.....	22
Zoning Systems Accessories .....	23
Zoning System Feature Comparison .....	25

## BUILDER SERIES Value Models

### Compatibility

- Single Stage Conventional or Heat Pump Systems
- Multistage Heat Pump Systems (1200NC, 2200NC)
- Multistage Conventional Systems (1200NC, 2200NC)
- 2-Wire Hydronic Zone Systems
- Millivolt Systems

### Features

- Adjustable Temperature Limits for Multi-Family Housing
- Hardwire or Battery Powered
- Permanent Memory Retains Settings
- Low Battery Indicator
- Front Access Reset Button
- Front Loading Battery Door
- Compressor Short Cycle Protection
- Fahrenheit or Celsius Display Mode
- Adjustable Temperature Differential
- ESD Guard™ Electronic Circuitry
- Trilingual Packaging and Instructions

### Additional Features (2000NC/2200NC)

- 5-2 Day Programmable
- Temporary Program Override
- Programmable Extended Hold Mode
- Filter Check Monitor
- Adaptive Recovery Mode (ARM™)

\*Complete Thermostat Feature Comparison on Page 24.

### Mechanical Thermostats



**500 (500C)\***  
1 Heat / 1 Cool

**505 (505C)\***  
Heat Only



\*Celsius Models 500C and 505C Available  
FREE Contractor Branding Available. See page 14.



**Bright  
Blue  
Display**

### Non-Programmable Thermostats

**1000NC - 1 Heat / 1 Cool**

**1200NC - 2 Heat / 1 Cool**



**Bright  
Blue  
Display**

### Programmable Thermostats

**2000NC - 1 Heat / 1 Cool**

**2200NC - 2 Heat / 1 Cool**





## BUILDER SERIES

### Compatibility

- Single Stage Conventional or heat Pump Systems
- Multistage Heat Pump Systems (1220NC, 2220NC)
- Multistage Conventional Systems (1220NC, 2220NC)
- 2-Wire Hydronic Zone Systems
- Millivolt Systems

### Features

- Large Display with Bright Blue Backlight
- Adjustable Temperature Limits for Multi-Family Housing
- Hardwire or Battery Powered
- Permanent Memory Retains Settings
- Low Battery Indicator
- Front Access Reset Button
- Compressor Short Cycle Protection
- Fahrenheit or Celsius Display Mode
- Adjustable Temperature Differential
- ESD Guard™ Electronic Circuitry
- Trilingual Packaging and Instructions

### Additional Features (2020NC/2220NC)

- 5-2 Day Programmable
- Temporary Program Override
- Programmable Extended Hold Mode
- Filter Check Monitor
- Adaptive Recovery Mode (ARM™)

\*Complete Thermostat Feature Comparison on Page 24.



**2**  
Sq. In.  
Display

### Non-Programmable Thermostats

**1020NC - 1 Heat / 1 Cool**

**1025NC - Heat Only**

**1220NC - 2 Heat / 1 Cool**



**2**  
Sq. In.  
Display

### Programmable Thermostats

**2020NC - 1 Heat / 1 Cool**

**2220NC - 2 Heat / 1 Cool**



FREE Color Contractor Branding on Quick Reference Instruction Card. See page 14.

## ECONOMY SERIES

### Compatibility

- Single Stage Conventional or heat Pump Systems
- Multistage Heat Pump Systems (1220, 2220)
- Multistage Conventional Systems (1220, 2220)
- 2-Wire Hydronic Zone Systems
- Millivolt Systems

### Features

- Large Display with Bright Blue Backlight
- Adjustable Temperature Limits for Multi-Family Housing
- Hardwire or Battery Powered
- Permanent Memory Retains Settings
- Low Battery Indicator
- Front Access Reset Button
- Compressor Short Cycle Protection
- Fahrenheit or Celsius Display Mode
- Adjustable Temperature Differential
- ESD Guard™ Electronic Circuitry
- Trilingual Packaging and Instructions

### Additional Features (2020/2220)

- 7 Day, 5-2 Day or Non-Programmable
- Temporary Program Override
- Programmable Extended Hold Mode
- Filter Check Monitor
- Adaptive Recovery Mode (ARM™)

\*Complete Thermostat Feature Comparison on Page 24.



### Non-Programmable Thermostats

1020 - 1 Heat / 1 Cool

1220 - 2 Heat / 2 Cool



### Universal Programmable Thermostats

2020 - 1 Heat / 1 Cool

2220 - 2 Heat / 2 Cool



FREE Color Contractor Branding on Quick Reference Instruction Card. See page 14.



**4**  
Sq. In.  
Display

## Non-Programmable Thermostats

**3020 - 2 Heat / 1 Cool**

**3220 - 3 Heat / 2 Cool**



**5**  
Sq. In.  
Display

## Universal Programmable Thermostats

**5020 - 2 Heat / 1 Cool**

**5220 - 3 Heat / 2 Cool**

## PREMIER SERIES

### Compatibility

- Single Stage Conventional or Heat Pump Systems
- Multistage Heat Pump Systems
- Multistage Conventional Systems (3220, 5220)
- 2 or 3-Wire Hydronic Zone Systems
- Millivolt Systems

### Features

- Large Display with Bright Blue Backlight
- Auto or Manual Changeover
- Hardwire or Battery Powered
- Permanent Memory Retains Settings
- Circulating Fan Mode
- Separate User and Installer Reset Buttons
- User Selectable Service Monitors
- Indoor or Outdoor Remote Sensing
- Multi-Level Keypad Lockout
- Heat Pump Balance Points
- Trilingual Packaging and Instructions

### Additional Features (5020/5220)

- 7 Day, 5-2 Day or Non-Programmable
- Residential or Commercial Modes
- Temporary Program Override
- Programmable Extended Hold Mode
- Programmable Fan Mode
- Adaptive Recovery Mode (ARM™)

\*Complete Thermostat Feature Comparison on Page 24.

**Contractors! Buy a Premier Series thermostat and get a FREE Braeburn thermostat guard or remote sensor.**

See Accessories - page 13.



FREE Color Contractor Branding on Quick Reference Instruction Card. See page 14.

## PREMIER SERIES

### Compatibility

- Single Stage Conventional or heat Pump Systems
- Multistage Heat Pump Systems (5320)
- Multistage Conventional Systems (5320)
- 2-Wire Hydronic Zone Systems
- Millivolt Systems

### Features

- 7 Day, 5-2 Day or Non-Programmable
- Auto or Manual Changeover
- Residential and Commercial Modes
- Hardwire or Battery Powered
- Permanent Memory Retains Settings
- Circulating and Programmable Fan Modes
- Separate User and Installer Reset Buttons
- User Selectable Service Monitors
- Indoor or Outdoor Remote Sensing
- Multi-Level Keypad Lockout
- Temporary Program Override
- Programmable Extended Hold Mode
- Adaptive Recovery Mode (ARM™)
- Trilingual Packaging and Instructions

### Additional Features (5320)

- Heat Pump Balance Points
- Auxiliary Fresh Air Terminal
- Auxiliary Heat Fossil Fuel Option

\*Complete Thermostat Feature Comparison on Page 24.



**6.5**  
Sq. In.  
Display

## Universal Touchscreen Thermostat

**5310 - 1 Heat / 1 Cool**

**5320 - 4 Heat / 2 Cool**

### SpeedBar® Multi-Function Button

Simplifies programming and set-up

### Large 6.5 Sq. In. Touchscreen with Oversized Characters

Easier to view and change settings

### SpeedSet® Programming Mode

Quickly program all 7 days

### Quick Reference Instruction Card

User instructions with FREE Color  
Contractor Branding



**Contractors! Buy a Premier Series thermostat and get a FREE Braeburn thermostat guard or remote sensor.**

See Accessories - page 13.



FREE Color Contractor Branding on Quick Reference Instruction Card. See page 14.





**12**  
Sq. In.  
Display

## Universal Touchscreen Thermostat

**6100 - 1 Heat / 1 Cool**

**6300 - 4 Heat / 2 Cool**

**6400 - 4 Heat / 2 Cool**   
with Humidity Control

### SpeedBar® Multi-Function Button

Simplifies programming and set-up

### Large 12 Sq. In. Touchscreen with Oversized Characters

Easier to view and change settings

### SpeedSet® Programming Mode

Quickly program all 7 days

### Quick Reference Instruction Card

User instructions with FREE Color Contractor Branding

## DELUXE SERIES

### Compatibility

- Single Stage Conventional or Heat Pump Systems
- Multistage Heat Pump Systems
- Multistage Conventional Systems (6300, 6400)
- 2-Wire Hydronic Zone Systems
- Millivolt Systems

### Features

- 7 Day, 5-2 Day or Non-Programmable
- Auto or Manual Changeover
- Residential and Commercial Modes
- Hardwire or Battery Powered
- Permanent Memory Retains Settings
- Circulating and Programmable Fan Modes
- Separate User and Installer Reset Buttons
- User Selectable Service Monitors
- Indoor or Outdoor Remote Sensing
- Multi-Level Keypad Lockout
- Temporary Program Override
- Programmable Extended Hold Mode
- Adaptive Recovery Mode (ARM™)
- Trilingual Packaging and Instructions

### Additional Features (6300/6400)

- Heat Pump Balance Points
- Auxiliary Fresh Air Terminal
- Auxiliary Heat Fossil Fuel Option
- Humidification and Dehumidification Control (6400)

\*Complete Thermostat Feature Comparison on Page 24.

**Contractors! Buy a Deluxe Series thermostat and get a FREE Braeburn thermostat guard or remote sensor.**

See Accessories - page 13.



FREE Color Contractor Branding on Quick Reference Instruction Card. See page 14.

**Wi-Fi Remote Access from Smartphone, Tablet or PC**



## 7205 3H / 2C Economical Smart Wi-Fi Solution

- 7 Day, 5-2 Day or Non-Programmable
- Large 3 sq. in. Backlit Display
- Auto or Manual Changeover
- User and Installer Lock Modes
- SmartLimit™ Temperature Limits
- Circulating Fan Mode

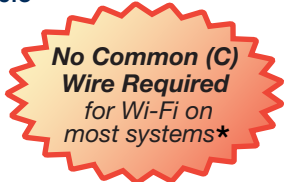

\* Wi-Fi works without common (C) wire on most systems. Requires common (C) wire on all Heat Pump, Heat Only or Cool Only Systems



## 7300 1H / 1C 7305 3H / 2C Affordable Smart Wi-Fi Solution

- 7 Day, 5-2 Day or Non-Programmable
- Large 5 sq. in. Backlit Display
- Auto or Manual Changeover
- Residential or Commercial Modes
- Programmable and Circulating Fan Modes
- Auxiliary Fresh Air Terminal
- Wired Remote Sensing (see page 13)
- Wi-Fi Requires Common (C) Wire



## 7320 3H / 2C Flexible Smart Wi-Fi Solution

- 7 Day, 5-2 Day or Non-Programmable
- Large 6.5 sq. in. Touchscreen Display
- Auto or Manual Changeover
- Residential or Commercial Modes
- Programmable and Circulating Fan Modes
- Auxiliary Fresh Air Terminal
- Wireless or Wired Remote Sensing )) (see page 13)
- Wi-Fi Requires Common (C) Wire



Phone not included.



FREE Color Contractor Branding on Quick Reference Instruction Card. See page 14.

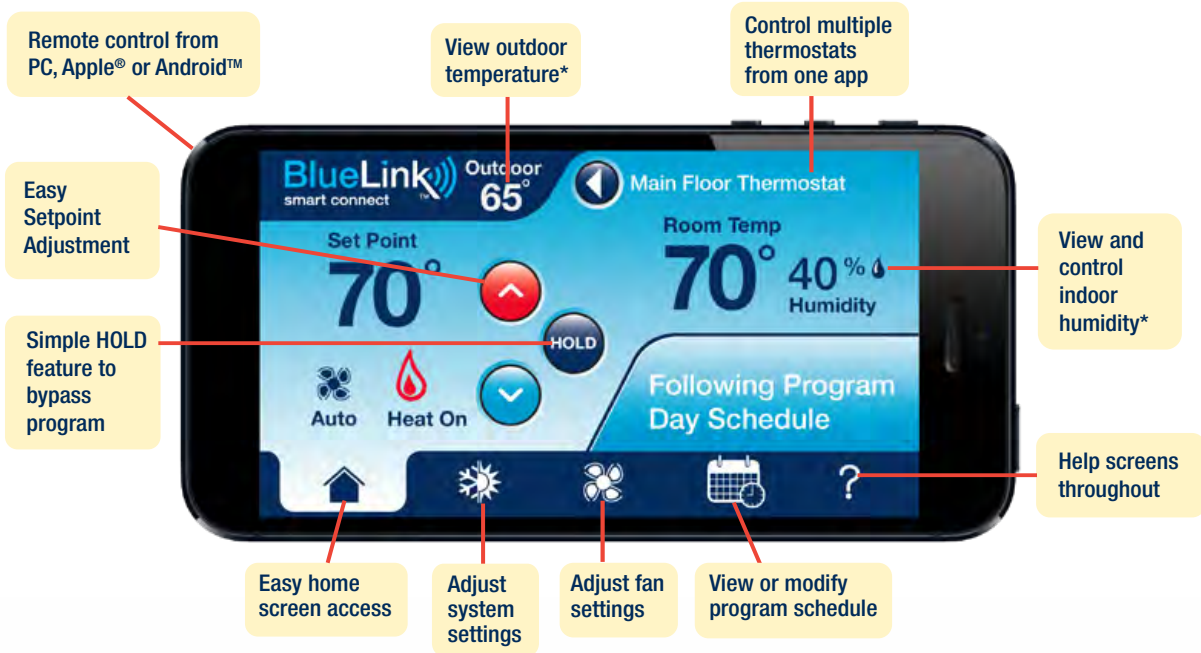

## Multi-Color Program Groups with QuickEdit®

Simplifies program scheduling by allowing the user to group days.



## QuickCopy Function

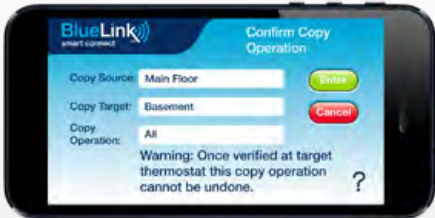

## Service & Temp Alerts



## Dealer Information

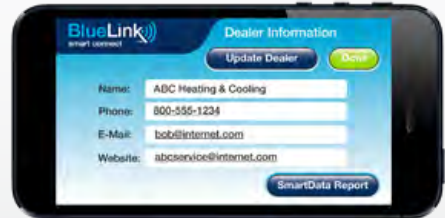

## BlueLink SmartData® Reports

Generate usage reports for your thermostat. Compatible with virtually all smartphones, tablets or PC's!



\*Feature only available on certain models.



BlueLink Application Help Available:  
[www.bluelinksmartconnect.com](http://www.bluelinksmartconnect.com)  
 Requires iOS or Android™ to connect





## 7500 3 Heat / 2 Cool Universal Wireless Thermostat Kit

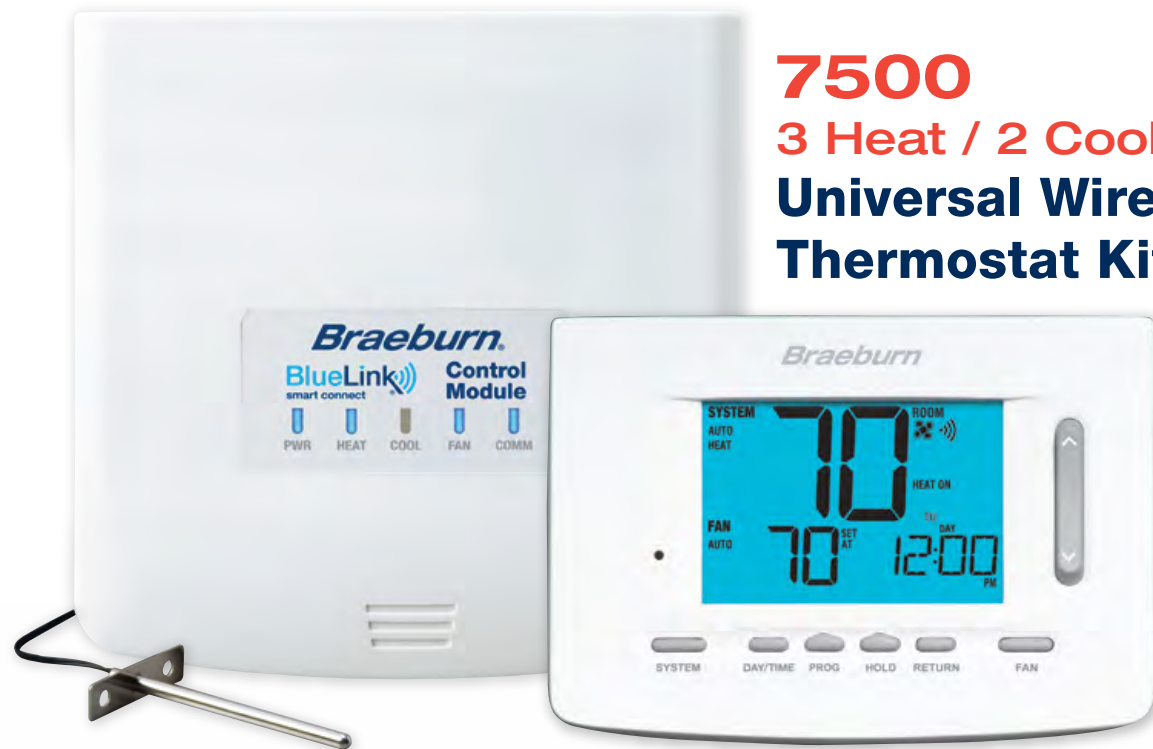

Compatible with Conventional and Heat Pump Systems, Up to 3H and 2C

Auto Changeover Selects Between Heating or Cooling

Auto, On and Programmable Fan Modes

7 Day, 5-2 Day or Non-Programmable Modes with SpeedSet®

Optional Wired Remote Indoor or Outdoor Sensing

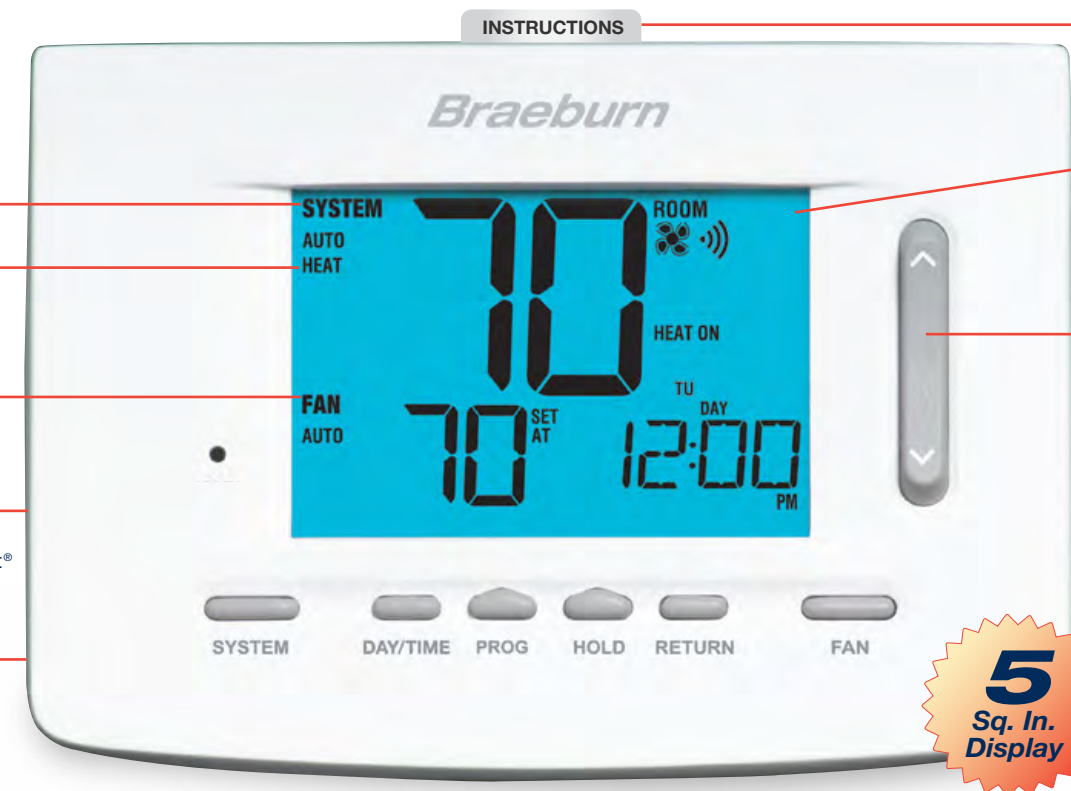

Quick Reference Instruction Card with FREE Color Contractor Branding

Large 5 sq. in. Display with Bright Blue Backlight

SpeedBar® Simplifies Programming and Setup

Optional Wireless Remote Indoor, Outdoor and Humidity Sensing



ACTUAL SIZE

## Complete Kit to Add or Relocate a Thermostat

### Thermostat Features

- 7 Day, 5-2 Day or Non-Programmable
- Large 5 Sq. In. Backlit Display
- Auto or Manual Changeover
- Residential or Commercial Modes
- Battery Operated for Total Installation Flexibility
- Compatible with 2 or 3-Wire Hydronic Systems
- Heat Pump Balance Points
- Auxiliary Heat Fossil Fuel Option
- Programmable Fan Mode
- R and C Terminals for Optional 24 Volt Operation
- Adjustable Temperature Limits
- Multi-Level Keypad Lockout

### Wireless Features

- Superior Wireless Range
- Battery Life Exceeds Virtually All Competitive Models
- Includes Return Air Sensor for Default Temperature Control Even if Batteries are Drained
- Connect up to 4 Optional Wireless Indoor Sensors for Remote Temperature Sensing\*
- Optional Wireless Outdoor Sensing for Outdoor Temperature Display or Balance Point Control\*
- Optional Wireless Humidity Plenum Sensor for Whole-House Humidification Control\*
- Affordable Solution for Most Thermostat Applications

## Total Installation Flexibility

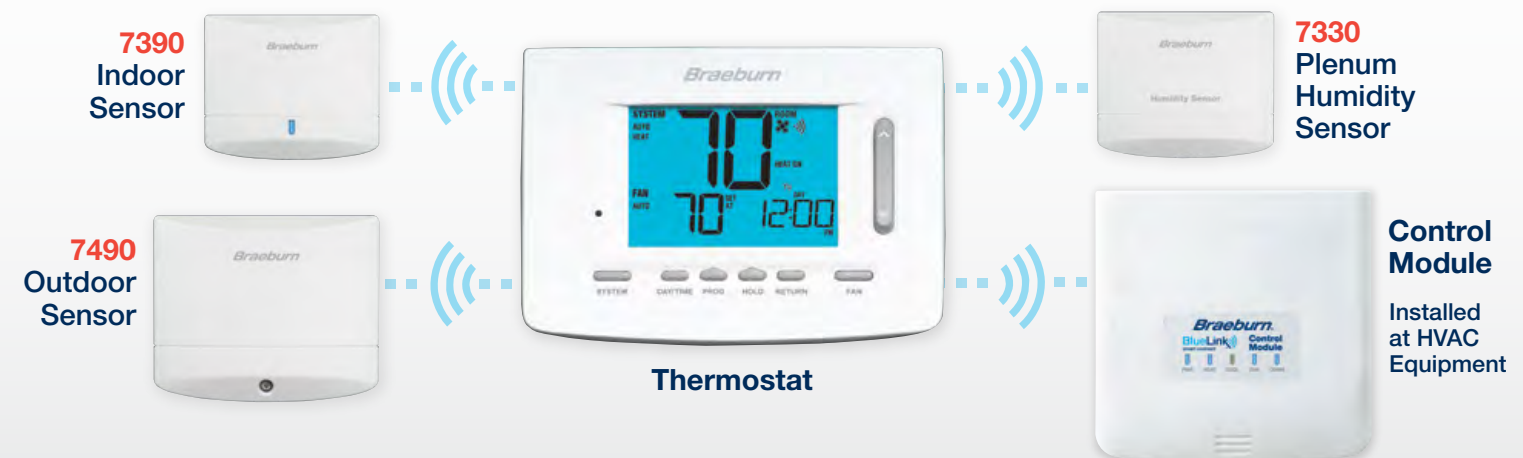

FREE Color Contractor Branding on Quick Reference Instruction Card. See page 14.



\* Up to 4 wireless Sensors can be connected - see Installer Guide.



# Thermostat Accessories

**Contractors! Buy a Premier or Deluxe series thermostat and get a FREE thermostat guard or wired remote sensor!<sup>1</sup>**



### 5390 Wired Remote Indoor Sensor

- Contemporary style for any decor
- For use with compatible Braeburn thermostats
- Sense range of 40° to 99°F

### 5490 Wired Remote Outdoor Sensor

- Mounts outdoors up to 200 feet away
- Enables outdoor control functions on compatible Braeburn thermostats
- Sense range of -40° to 120°F



### 5970 Thermostat Guard

- Universal—fits virtually all thermostats
- Replaces over 100 competitive models
- Tamper resistant design
- Two keys Included
- Fits thermostats up to 7.3"W x 5.25"H x 1.8"D

### 165 Construction Thermostat

- Install in place of standard 24 Volt AC thermostat during construction
- Maintains fixed temperature set point of 65° heat
- Sturdy enclosure protects switch from drywall dust, paint and mudding

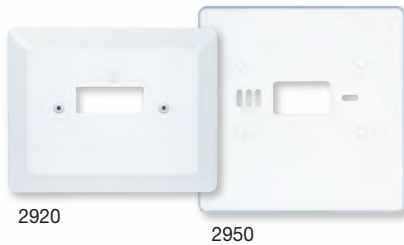

### 2920 Vertical Wall Plate

- Adapts vertical J box to horizontal mount
- Sturdy two piece construction
- 6.5"W x 5 1/8"H

### 2950 Universal Wall Plate

- Covers mounting marks from old thermostats
- Use with all Braeburn digital thermostats
- 6.5"W x 6.5"H

## BlueLink<sup>®</sup> Wi-Fi and Wireless Accessories



### 7390 Wireless Remote Indoor Sensor<sup>2</sup>

- Sense temperature at remote location or average with thermostat
- Up to 4 wireless remote indoor sensors can be connected
- Front LED light shows sensor status
- Requires 2 "AA" Alkaline batteries (included)



### 7490 Wireless Remote Outdoor Sensor<sup>2</sup>

- Display outdoor temperature
- Use for heat pump balance point control
- 1 wireless remote outdoor sensor can be connected
- Requires 2 "AA" Lithium batteries (included)



### 7330 Wireless Remote Humidity Sensor<sup>2</sup>

- Controls humidifier or dehumidifier
- Mounts directly to return air plenum
- 1 wireless remote humidity sensor can be connected
- 24 VAC Powered



### 7340 Share-a-Wire<sup>®</sup> Module

- For use with BlueLink<sup>®</sup> Wi-Fi Thermostats
- Provides a common "C wire" connection on a 4-wire system
- Install near system control board

<sup>1</sup>Visit [www.braeburnonline.com](http://www.braeburnonline.com) for details. <sup>2</sup>For use with models 7320 and 7500 - a maximum of 4 wireless remote sensors can be connected.

# FREE Contractor Branding - in Color!

## Send us your color logo and we'll promote your brand for FREE

With Braeburn, there are no minimum purchase requirements for the contractor to advertise 24 hours a day in customers' homes. Your logo and contact information will be readily available when it is time for maintenance or equipment repair.

Non-branded Quick Reference cards are already included with our thermostats. For custom branded cards, simply send us your logo and we will ship you custom printed cards absolutely FREE.

## Easy Ordering

### FREE Quick Reference Cards with Color Logo

- Visit [www.braeburnonline.com/contractorbranding](http://www.braeburnonline.com/contractorbranding)
- Upload your high resolution logo in TIF, JPG or EPS format
- Contractors will receive 50 full color Contractor Branded Quick Reference Cards for FREE, with no set-up fees or branding charges.
- Please allow 2-3 weeks for delivery

### FREE Battery Doors or Labels

- Visit [www.braeburnonline.com/contractorbranding](http://www.braeburnonline.com/contractorbranding)
- Provide 3 lines of text (no logos) - 30 characters per line
- Contractors will receive 50 doors or labels for FREE, with no set-up fees or branding charges.
- Please allow 2-3 weeks for delivery



## ECONOMY SERIES

### Compatibility

- Single Stage Conventional or Heat Pump Systems
- Multistage Conventional or Heat Pump Systems
- Single Stage Conventional Thermostats - For Lower Cost
- Power Open, Power Close or Spring Return Dampers

### Features

- Sleek, Low Profile Design
- Quick Connect Terminals Speed Installation
- On-Board Emergency Heat Switch
- Ability to Connect External Emergency Heat Switch
- Selectable Zone Priority
- Fan Purge Into Last Calling Zone
- Easy-Set Dip Switches
- Heavy Duty 10-Amp Relays
- Short Cycle Protection Jumper
- Zone Calling Status LED's

### Additional Features (140303)

- On-Board LED Display
- Supply Air Sensor Included
- Adjustable Purge Control
- Thermostat Status LED's
- Equipment Status LED's
- 2-Stage Fan Control
- Advanced Staging

\*Complete Zoning Feature Comparison on Page 25.



**2-Zone Control Panel**  
**140202**  
**2 Heat / 1 Cool**



**3-Zone Control Panel**  
**140303**  
**3 Heat / 2 Cool**



## 140202

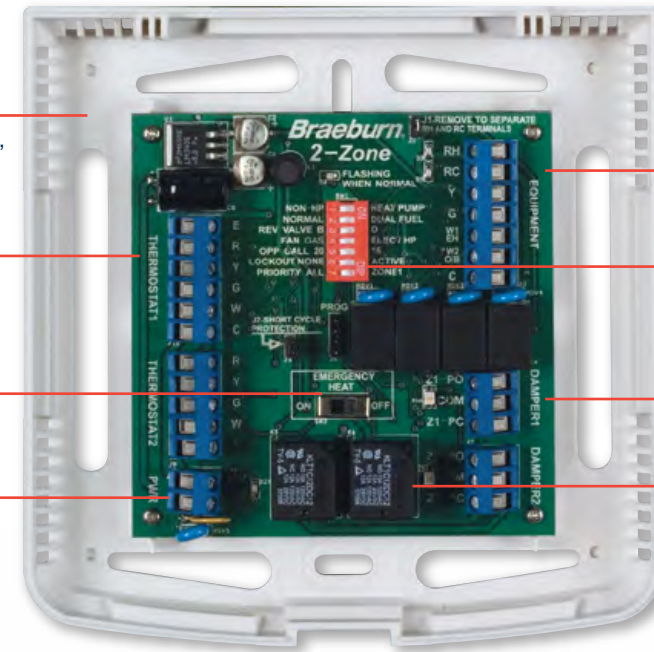

### Flexible System Options

Controls conventional, heat pump, electric, and dual fuel systems

### Thermostat Terminals

Use with conventional 4 or 5 wire thermostats

### Emergency Heat Switch

With remote terminals

### Power Terminals

Accepts standard 24 VAC power from transformer. Built in self-resetting fuse helps protect panel

### Equipment Terminals

Simple equipment connections

### Easy-Set Dip Switches

Select system preferences

### Damper Terminals

With LED indicators

### Heavy Duty Relays

10-Amp capacity for extra durability

Compact 6" x 6" Housing

## 140303

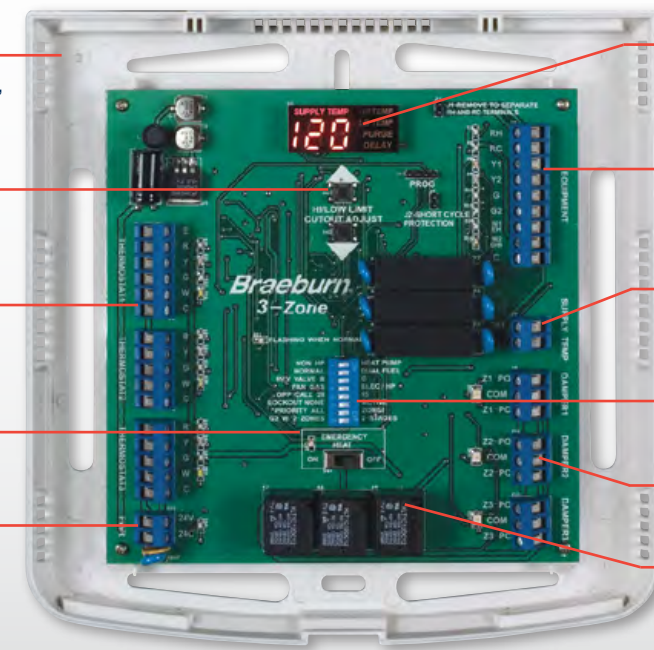

### Flexible System Options

Controls conventional, heat pump, electric, and dual fuel systems

### Adjustable Purge Control

Maximizes economy and occupant comfort

### Thermostat Terminals

Use with conventional 4 or 5 wire thermostats

### Emergency Heat Switch

With remote terminals

### Power Terminals

Accepts standard 24 VAC power from transformer. Built in self-resetting fuse helps protect panel

### LED Display

Easy to read LED display shows system temperature and purge status

### Equipment Terminals

Simple equipment connections with LED status indicators

### Supply Air Sensor

Monitors plenum temperature and provides adaptive staging

### Easy-Set Dip Switches

Select system preferences

### Damper Terminals

With LED indicators

### Heavy Duty Relays

10-Amp capacity for extra durability

Compact 8" x 8" Housing



**NEW**



**2-Zone Control Panel**  
**140221 - 2 Heat / 1 Cool**

## PREMIER SERIES

### Compatibility

- Single Stage Conventional or Heat Pump Systems
- Multistage Conventional or Heat Pump Systems
- Single Stage or Multistage Thermostats
- Power Open, Power Close or Spring Return Dampers

### Features

- Large Display with Bright Blue Backlight
- Push-In Terminals For Easy Wiring
- On-Board Emergency Heat Switch
- Ability to Select Emergency Heat From Thermostat
- Selectable Zone Priority
- Adjustable Purge Control
- Built-In Test Mode
- Easy Setup and Configuration
- Heavy Duty 10-Amp Relays
- Flexible Staging Controlled by Panel or Thermostats
- Dual Fuel Control with Optional Outdoor Sensor
- System Reset Button
- Thermostat Status LED's
- Equipment Status LED's
- Zone Calling Status LED's

### Additional Features (140332)

- Optional Supply Air Sensor For Limit Protection
- 2-Stage Fan Control

\*Complete Zoning Feature Comparison on Page 25.

**NEW**



**3-Zone Control Panel**  
**140332 - 3 Heat / 2 Cool**

### Flexible System Options

Controls conventional, heat pump, electric, and dual fuel systems

### Flexible Thermostat Options

Works with virtually any low voltage heat pump or conventional thermostat

### Built In Test Mode

Test all dampers and equipment from panel

### Outdoor Sensor Terminals

Connect to Braeburn outdoor sensor for heat pump balance point control

**140221**

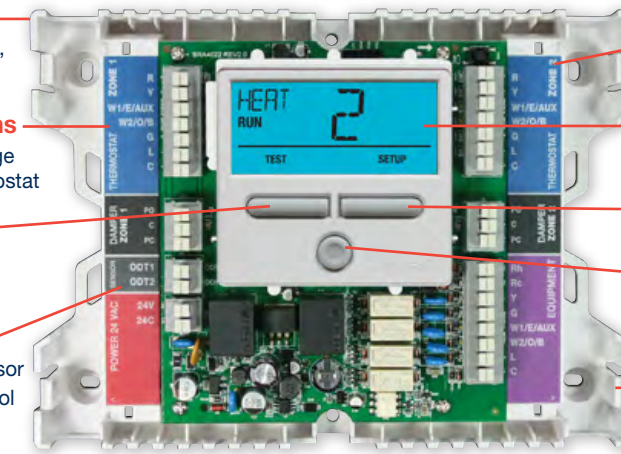

**Compact 8" x 6" Housing**

### Thermostat Terminals

Push-in wiring terminals with LED status indicators

### Large Display

3 sq. in. backlit display

### Easy 2 Button Setup

Set up and test from main display

### Emergency Heat Button

Panel mounted button and selectable thermostat emergency heat control

### Professional Appearance

Wire along side and underneath with multiple wire tie points

### Flexible System Options

Controls conventional, heat pump, electric, and dual fuel systems

### Built In Test Mode

Test all dampers and equipment from panel

### Damper Terminals

Push-in wiring terminals with LED status indicators

### Flexible Thermostat Options

Works with virtually any low voltage heat pump or conventional thermostat

### Professional Appearance

Wire along side and underneath with multiple wire tie points

**140332**

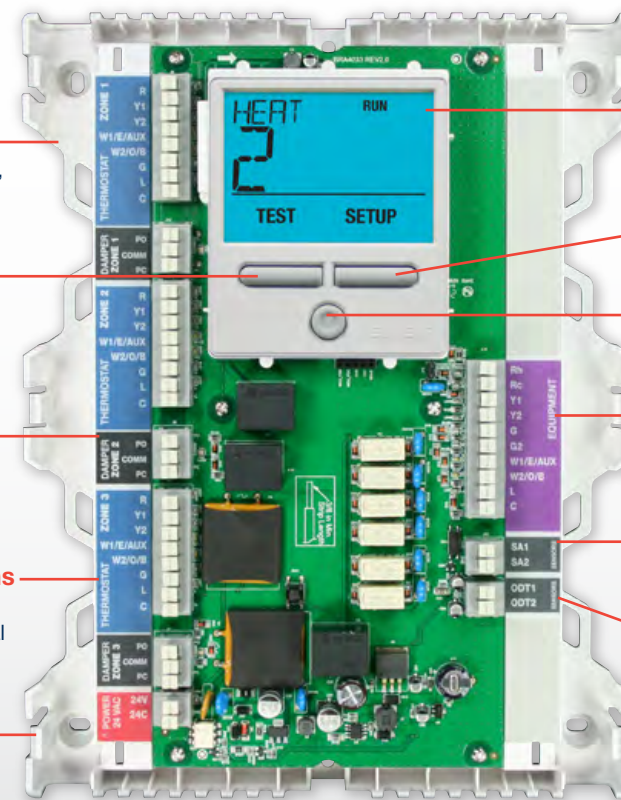

**Compact 8" x 10" Housing**

### Large Display

5.5 sq. in. backlit display

### Easy 2 Button Setup

Set up and test from main display

### Emergency Heat Button

Panel mounted button and selectable thermostat emergency heat control

### Equipment Terminals

Simple push-in wiring terminals with LED status indicators

### Supply Air Sensor (optional)

Stainless steel sensor controls high and low temperature cutout

### Outdoor Sensor Terminals

Connect to Braeburn outdoor sensor for heat pump balance point control







## 4-Zone Expandable Control Panel

**140404 - 4 Heat / 2 Cool**

Use with 140404 Zone Panel



## 2-Zone Expander Panel

**140424 - 4 Heat / 2 Cool**

## PREMIER SERIES

### Compatibility

- Single Stage Conventional or Heat Pump Systems
- Multistage Conventional or Heat Pump Systems
- Single Stage or Multistage Thermostats
- Power Open, Power Close or Spring Return Dampers

### Features

- Expandable up to 32 Zones
- Large Display with Bright Blue Backlight
- Includes Supply Air Sensor for Staging and Limit Protection
- Push-In Terminals For Easy Wiring
- On-Board Emergency Heat Switch
- Ability to Select Emergency Heat From Thermostat
- Selectable Zone Priority
- Adjustable Purge Control
- Built-In Test Mode
- Easy Setup and Configuration
- Heavy Duty 10-Amp Relays
- Flexible Staging Controlled by Panel or Thermostats
- Dual Fuel Control with Optional Outdoor Sensor
- System Reset Button
- Fire Alarm Terminals
- 2-Stage Fan Control
- Thermostat Status LED's
- Equipment Status LED's
- Zone Calling Status LED's

### Additional Features (140424)

- Add Zones in Affordable 2-Zone Increments
- Installs Up to 500 Ft. from Main Panel
- Stacks Neatly with Main Panel

\*Complete Zoning Feature Comparison on Page 25.

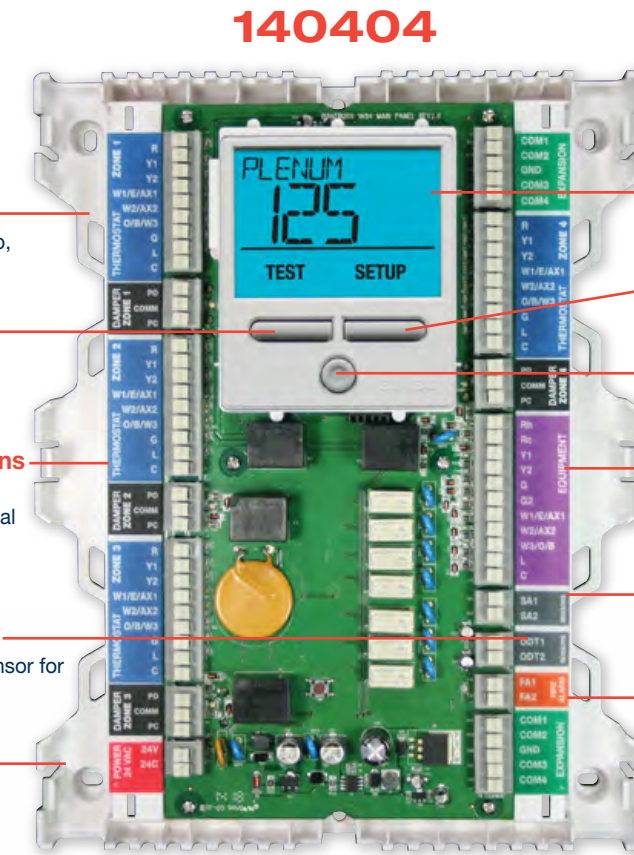

**Compact 8" x 10" Housing**

### Flexible System Options

Controls conventional, heat pump, electric, and dual fuel systems

### Built In Test Mode

Test all dampers and equipment from main panel

### Flexible Thermostat Options

Works with virtually any low voltage heat pump or conventional thermostat

### Outdoor Sensor Terminals

Connect to Braeburn outdoor sensor for heat pump balance point control

### Professional Appearance

Wire along side and underneath with multiple wire tie points

### Large Display

5.5 sq. in. backlit display

### Easy 2 Button Setup

Set up and test from main display

### Emergency Heat Button

Panel mounted button and selectable thermostat emergency heat control

### Equipment Terminals

Simple push-in wiring terminals with LED status indicators

### Supply Air Sensor Included

Stainless steel sensor helps control staging and high / low temperature cutout

### Fire Alarm Terminals

Selectable for normally open or closed

## 140424

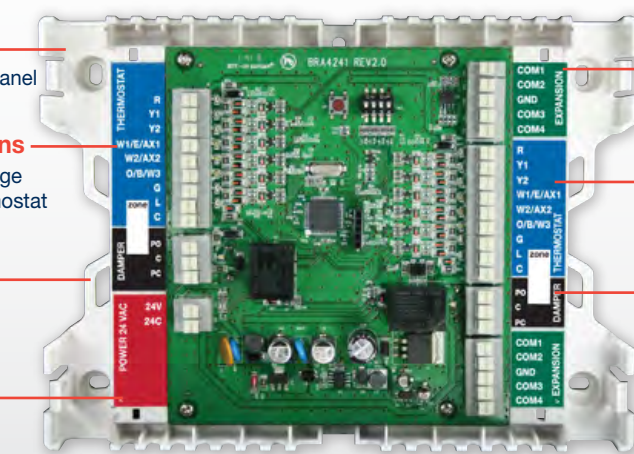

**Compact 8" x 6" Housing**

### Flexible System Options

Install up to 500 feet from main panel

### Flexible Thermostat Options

Works with virtually any low voltage heat pump or conventional thermostat

### Professional Appearance

Wire along side and underneath with multiple wire tie points

### Power Terminals

Accepts standard 24 VAC power from transformer. Built in self-resetting fuse helps protect panel

### Easy to Wire

Use standard 5-wire thermostat wire from panel to panel

### Thermostat Terminals

Push-in wiring terminals with LED status indicators

### Damper Terminals

Push-in wiring terminals with LED status indicators

### Easy Setup

Set zone number on main panel



## Round Zone Dampers

### Power Open / Power Close

24 VAC 4 VA 3-wire universal operation



Power Open / Power Close

Power Open Power Close	Diameter (Inches)	Length (Inches)	Power Open Power Close	Diameter (Inches)	Length (Inches)
109005	5	11.25	109012	12	11.75
109006	6	11.25	109014	14	13.75
109007	7	11.25	109016	16	15.75
109008	8	11.25	109018	18	17.75
109009	9	11.25	109020	20	19.75
109010	10	11.25			



Spring Return

### Spring Return

- 24 VAC 8 VA 2-wire universal operation
- Available in Power Close / Spring Return and Power Open / Spring Return

### Static Bypass

- Vertical or horizontal mounting
- Reversible control for flexible mounting

Power Close Spring Return	Power Open Spring Return	Static Bypass	Diameter (Inches)	Length (Inches)
119004	129004	-	4	9.75
119005	129005	-	5	9.75
119006	129006	-	6	9.75
119007	129007	119107	7	9.75
119008	129008	119108	8	9.75
119009	129009	119109	9	9.75
119010	129010	119110	10	9.75
119012	129012	119112	12	11.75
119014	129014	119114	14	13.75
119016	129016	119116	16	15.75
119018	129018	119118	18	17.75
119020	129020	119120	20	19.75

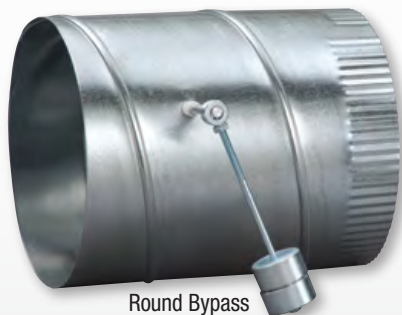

Round Bypass

### Retrofit (PO/PC)

24 VAC 4 VA 3-wire universal operation



Retrofit

Round Retrofit (PO / PC)	Diameter (Inches)	Round Retrofit (PO / PC)	Diameter (Inches)
128004	4	128007	7
128005	5	128008	8
128006	6	128010	10



## Rectangular Zone Dampers

### Power Open / Power Close

- For use as zone or bypass damper
- 24 VAC 4 VA universal operation



Power Open /  
Power Close



Power Close /  
Spring Return

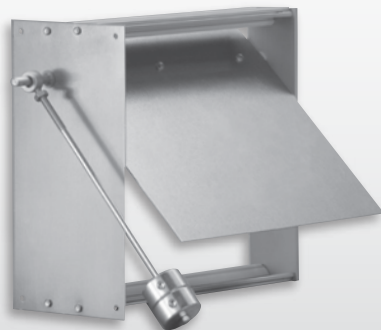

Rectangular  
Bypass

#### Height in Inches

	8	10	12	14	16
8	100808	—	—	—	—
10	101008	101010	101012	101014	—
12	101208	101210	101212	101214	—
14	101408	101410	101412	101414	—
16	101608	101610	101612	101614	101616
18	101808	101810	101812	101814	101816
20	102008	102010	102012	102014	102016
22	102208	102210	102212	102214	102216
24	102408	102410	102412	102414	102416
26	102608	102610	102612	102614	102616
28	—	—	—	102814	102816
30	—	—	—	103014	103016

Width in Inches

All motors are mounted on the Height Dimension

### Power Close / Spring Return

- 2 wire installation
- 24 VAC 8 VA universal operation

#### Height in Inches

	8	10	12	14	16
8	110808	—	—	—	—
10	111008	111010	111012	111014	—
12	111208	111210	111212	111214	—
14	111408	111410	111412	111414	—
16	111608	111610	111612	111614	111616
18	111808	111810	111812	111814	111816
20	112008	112010	112012	112014	112016
22	112208	112210	112212	112214	112216
24	112408	112410	112412	112414	112416
26	112608	112610	112612	112614	112616
28	—	—	—	112814	112816
30	—	—	—	113014	113016

Width in Inches

All motors are mounted on the Height Dimension

### Rectangular Static Bypass

#### Height in Inches

	8	10	12
12	131208	131210	131212
20	132008	132010	132012

Width in Inches





## Zoning Systems Accessories

Braeburn Zoning Accessories are designed to give years of performance in demanding zoning applications. Complete the HVAC installation with the full line of Braeburn thermostats and guards.

### 149020 Static Pressure Control

The Braeburn static pressure control is designed to mount on vertical surfaces. Powered from the zone panel transformer, this unit automatically controls the plenum bypass damper by monitoring system pressure as zones close and open.

#### Features

- Used to control plenum bypass air volume
- Reduces bypass problems in mismatched zones
- Includes relay and measuring pitot tube

### 149040 Zoning System Transformer

Braeburn zoning transformers have 120 VAC input and 24 VAC output. UL listed and convenient mounting features for easy installation.

#### Features

- 40 VA, 120 VAC
- Includes mounting plate

### Emergency Heat Switch Kit

These kits are the finishing touch to any zoning system installation. More convenient than the remote switch on the zone panel, both kits include a laser engraved wall plate and handy box.

#### Features

- 149090 features a commercial quality lighted rocker switch
- 149091 features a standard switch

### Replacement Parts

- 149100 Synchron Motor for Round PO/SR Dampers
- 149125 Motor for All PO/PC Dampers (except retrofit)
- 149145 Motor for All PO/SR Dampers
- 149156 Supply Air Sensor
- 149160 Barometric Bypass Damper Counterweight
- 149162 Barometric Bypass Damper Arm Assembly

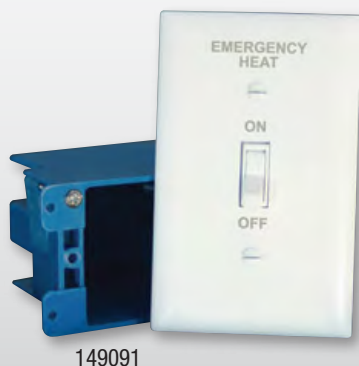
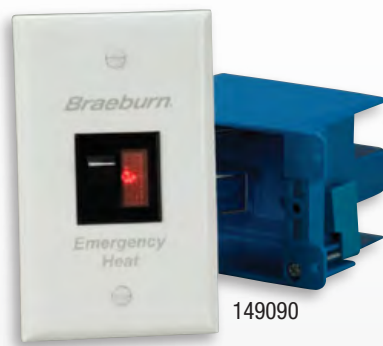
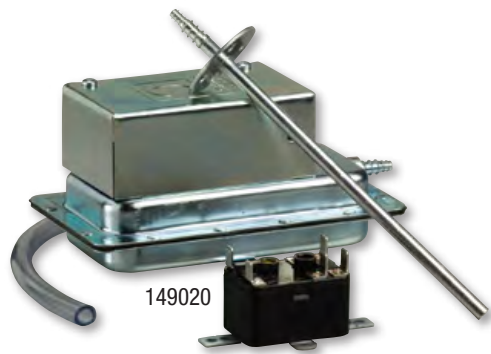



## Your Value Source for Indoor Comfort



### Humidification

Braeburn Humidifiers offer an economical solution to whole house humidification! Choose from 12, 17 or 18 gallon bypass and fan powered humidifiers. All models include a manual or digital humidistat.

### Air Filtration

Braeburn Air Cleaners are the value solution to satisfy today's residential and light commercial air filtration needs. Six easy to install cabinets can replace over 35 competitive models.



*Ask your Braeburn sales team for more information and catalogs.*

# Braeburn® Products



Welcome! Braeburn is the value alternative for a wide variety of indoor air quality control products. Founded in 2001, our corporate headquarters is located in Montgomery, Illinois – just west of Chicago. We are committed to providing you with the precision products you would expect from a world class company. Our manufacturing facility is ISO 9001 and QS9000 rated for the highest assurance of quality. Braeburn provides solutions to lower energy costs and increase comfort in any home or business environment. Our innovative value-added features, reliability and contemporary designs make us the brighter choice in thermostats, air filtration products, humidification and zoning.



*We support the*  
**Energy Aware  
Program**

[www.getenergyaware.com](http://www.getenergyaware.com)

Customer Service North America: +1.800.304.6563  
Customer Service South America: +1.800.304.6563  
Customer Service Europe: +420.587.805.191  
Customer Service Australia and New Zealand: +61.296.317999  
Customer Service India: +91.20.4912.3300  
[HVACCustomerService@robertshaw.com](mailto:HVACCustomerService@robertshaw.com)