

APPLICATION

The Paragon® ERC-2 Electronic Refrigeration Control is a microprocessor-based electronic controller designed to control both the temperature and the defrost functions of a commercial refrigeration unit. It can be powered by 120, 208 or 240V AC (50 or 60 Hz). The control comes with four relay outputs: compressor, defrost, evaporator fan and alarm.

The ERC-2 includes a digital display module that provides readout of the temperature, time and built-in diagnostics. The display module can be mounted locally or remotely from the unit and it contains a touch keypad for simple programming. For defrost control, it uses a real time clock.

This control is NSF certified and it can be applied to many different commercial refrigeration applications like reach-ins, walk-ins, refrigerated cases or other different products where accurate control of refrigerated space and defrost cycles are required.

FEATURES / BENEFITS

- **Multi-function Unit**
Integrates defrost timer, temperature control, defrost termination switch, fan delay switch and digital thermometer
- **Display Module for Temperature Readout**
Easy to read display that can be mounted with the unit or remotely. Temperature can be displayed in °F or °C
- **Two Temperature Sensors**
For zone temperature and evaporator temperature
- **Choice of Defrost Methods**
Off cycle, hot gas or electric heater with up to 8 defrosts per day and duration up to 4 hours
- **Four Relay Outputs**
Compressor, defrost, evaporator fan and alarm
- **Adjustable Short Cycle Protection**
Extra protection for the equipment
- **Non-volatile memory**
The programmed parameters will remain in the memory
- **Capacitor Carry Over for the Clock**
It maintains the correct time-of-day for up to 100 hours
- **Microprocessor-Based Electronics**
High reliability and repeatability

FCC COMPLIANCE*

This device complies with CFR 47, Part 15, Class A FCC requirements. Operation is subject to the following two conditions (1) This device may not cause harmful interference and (2) This device must accept any interference received, including interference that may cause undesired operation.

CANADIAN COMPLIANCE*

This digital apparatus meets all of the Industry Canada, ICES-003, Class A requirements (Canadian Interference-Causing Equipment Regulations).

* **Note:** These compliances apply to NEMA 1 enclosed models only. All modular units are the responsibility of the purchaser to obtain the compliance.



OPERATION AND FUNCTIONS

The ERC-2 features a simple way to program and operate. Four buttons on the display module allow the user to scroll through the functions and set the desired parameters. A manual defrost button is used to initiate the defrost cycle at any time.

There are two different levels of security to access the programming features. The first one will allow the change on the time-of-day and the setpoint temperature (cut-out). The other level will allow access to the other parameters.

The programmable parameters are:

Clock

- Clock: allows time-of-day programming and choice of display format (12 / 24 hours)

General

- Display: the display can show time-of-day, zone temperature, evaporator temperature and it can also cycle between zone temperature and time-of-day
- Temperature format: the control can use temperatures in °F or °C
- Fan enable during defrost: to control the fan operation during defrost (on or off)
- Minimum compressor off time: for short cycle protection, between 0 and 15 minutes
- Minimum compressor on time: between 0 and 15 minutes
- Alarm delay: a time delay can be configured for the alarm to operate, between 0 and 59 minutes

OPERATION AND FUNCTIONS (Continued)

Defrost

- Defrost type: it can programmed for hot gas or electric heater defrost. An off cycle defrost type can be configured by selecting the electric defrost option and not connecting any device to the defrost relay.
- Number of defrosts per day: between 1 and 8. There is also an option for 1 defrost every 48 hours.
- Defrost cycle: a choice among defrost start time (real time clock), accumulated compressor run time or temperature initiation defrost
- Fan delay: amount of time that the fan will remain off after defrost is terminated (0 to 15 minutes).
- Pump down: amount of time the compressor remains on after defrost initiates (0 to 59 minutes).
- Drip time: amount of time the compressor remains off after defrost is terminated (0 to 59 minutes).
- Defrost duration time: amount of time for the defrost duration. It also functions as a back-up for temperature termination.
- Defrost termination temperature: temperature that will cause the defrost to terminate (if reached before defrost duration time).
- Fan start temperature: temperature that will cause the fan to re-start after defrost.

Setpoint

- Setpoint temperature (cut-out): a setpoint temperature can be programmed to control the compressor operation. The range is -40° to 60°F.
- Cut-in differential: differential between the cut-out (setpoint) and the cut-in temperature. The range is 1° to 25°F.
- High and low temperature alarm setpoint: high and low alarms for the temperature can be set. The ranges are -40° to 60°F for each of the alarms (high and low).

GRAPHIC DESCRIPTION / DIMENSIONS

Display Layout

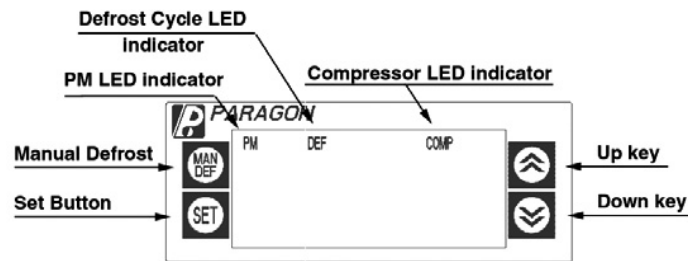

Figure. 1

Relay Board Layout

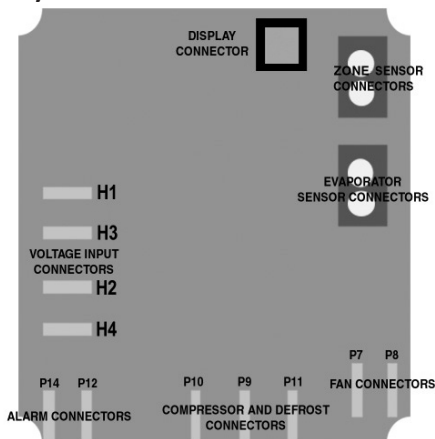

Figure. 2

Overall Dimensions - Models ERC2 – 111xxx and 211xxx (Metal Case / Integrated Display Module)

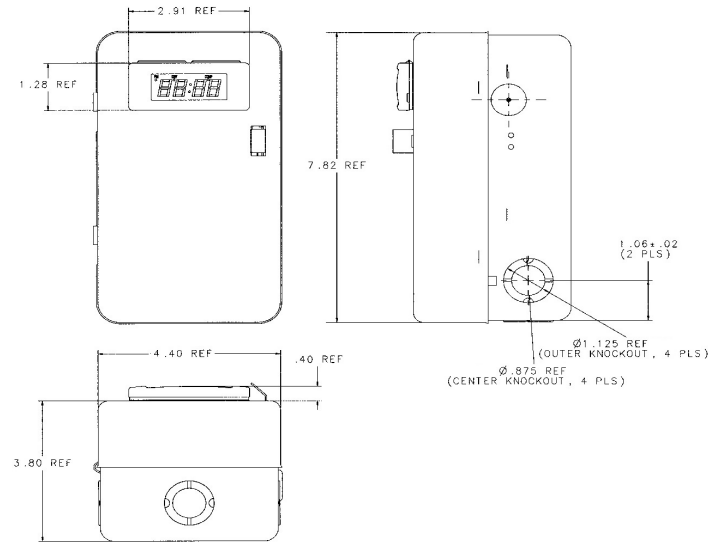

Figure. 3

Models ERC-2 – 121xxx and 221xxx (Metal Case / Remote Display Module)

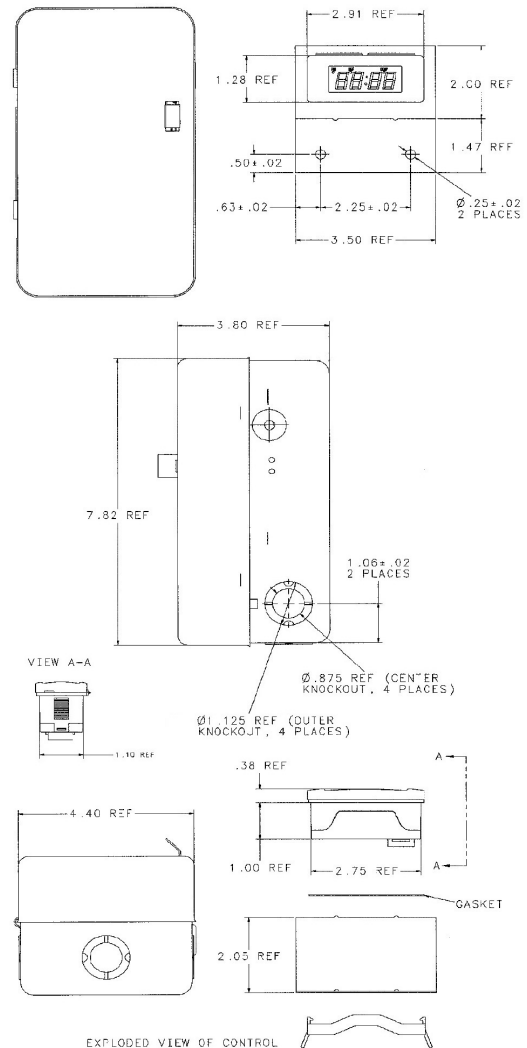

Figure. 4

**Model ERC2 – 131xxx, 151xxx, and 351xxx
(Control Mechanism / Remote Display Module)**

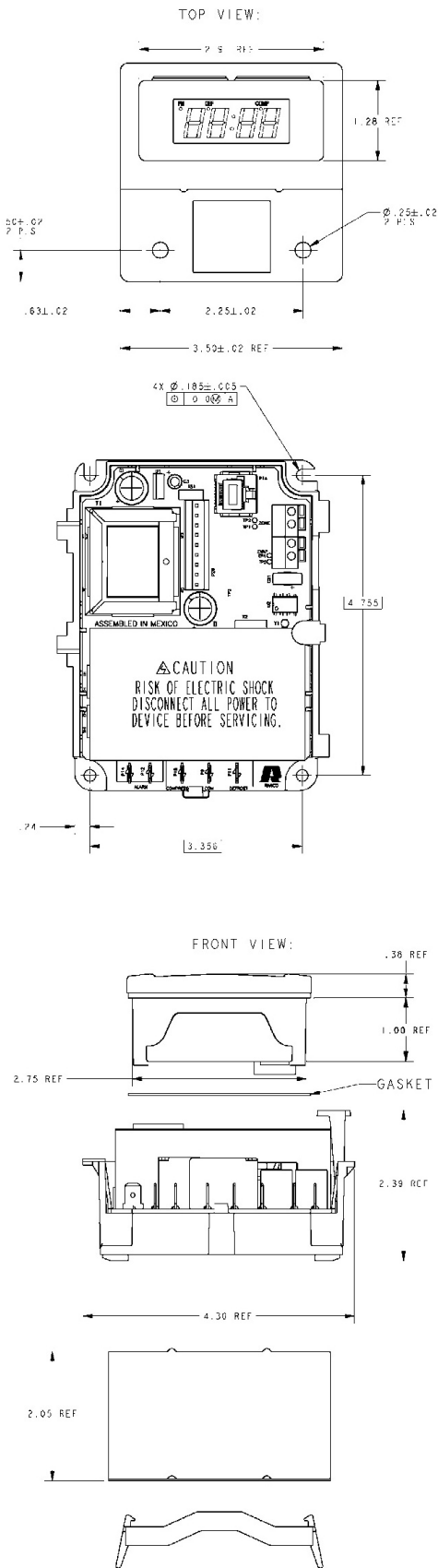



Figure 5

INSTALLATION INSTRUCTIONS

IMPORTANT

- All ERC-2 series controls are designed as operating controls only. If an operating control failure could result in personal injury or loss of property, a separate safety control and/or alarm should be installed.
- The schematic drawings and other information included in this specification sheet are for the purpose of illustration and general reference only.
- These instructions do not expand, reduce, modify or alter the Robertshaw Terms in any way; and no warranty or remedy in favor of the customer or any person arises out of these instructions.
- The ERC-2 control has been certified by Underwriters Laboratories Inc. The certification does not extend to their use for any other purpose. Robertshaw assumes no responsibility for any unconventional application of its control unless such application has been approved in writing by Robertshaw.
- It is the responsibility of the installer and the user to assure that his or its application and use of Robertshaw products are in compliance with all federal, state and local requirements, including, without limitation, all requirements imposed under the National Electric Code and any applicable building codes.



CAUTION

TO PREVENT POSSIBLE ELECTRIC SHOCK OR EQUIPMENT DAMAGE, DISCONNECT ELECTRICAL POWER TO THE UNIT BEFORE AND DURING INSTALLATION. **DO NOT** RESTORE ELECTRICAL POWER TO THE UNIT UNTIL THE CONTROL IS PROPERLY INSTALLED AND THE CASE OR PANEL DOOR IS CLOSED. DO NOT LOCATE THE CONTROL IN AN EXPLOSIVE ATMOSPHERE AS A SAFETY HAZARD CAN RESULT DUE TO POSSIBLE SPARK GENERATION IN THE CONTROL. USE OF CONTROL IN SUCH ENVIRONMENTS MAY RESULT IN INJURY OR DAMAGE OF THE PERSONS OR PROPERTY (OR BOTH) AND ARE LIKELY TO SHORTEN CONTROL LIFE. **ROBERTSHAW ASSUMES NO RESPONSIBILITY FOR ANY SUCH USE.**

Mount the ERC-2 to a wall or any flat surface using the three holes in the metal case (models ERC-2 - x11xxx and x21xxx) or the 4 holes in the plastic support for the ERC-2 - 131xxx, 151xxx, and 351xxx models. The control's components are not position sensitive, but should be mounted so they can be easily wired and adjusted. The models that do not come in a metal case must be mounted inside an enclosure (NEMA 1 type or better). Avoid excessive conditions of moisture, dirt, dust and any corrosive atmosphere.

Mounting Dimensions – Metal Case

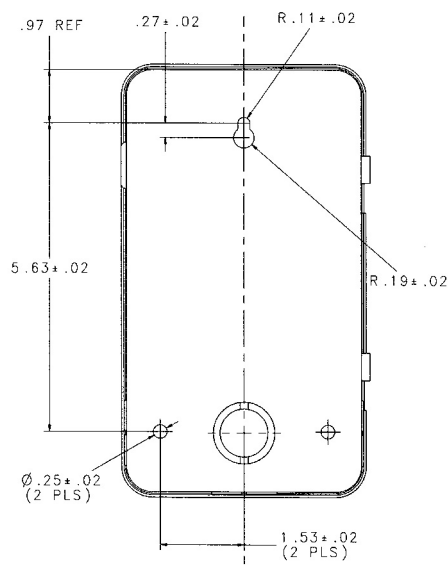

Figure 6

CONTROL WIRING

- All wiring should conform to the National Electric Code and local regulations
- Use copper conductors only
- Electrical leads should not be taut; allow slack for temperature change and vibration

The wiring diagrams for the ERC-2 are shown below:

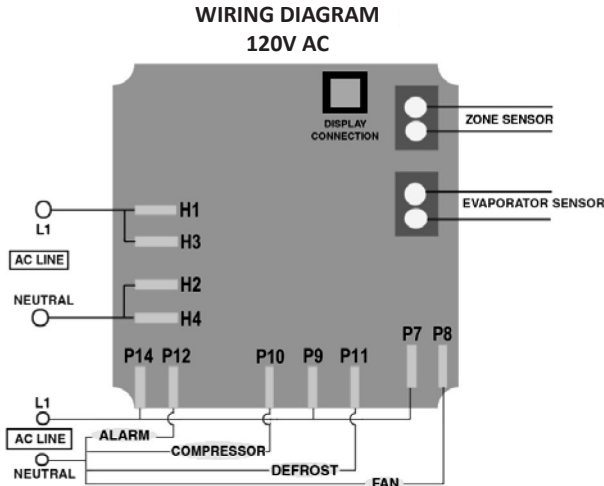

Figure. 7

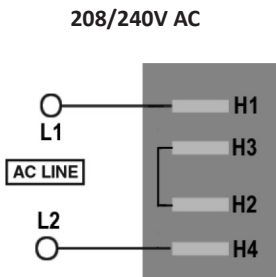

Figure. 8

Wiring Installation Procedure

Accessing the terminals

1. Open the metal case to access the control connectors. The cable can be disconnected from the display module while the control is being wired. Reconnect the cable before using the unit.

Connecting the sensors

1. Connect the evaporator sensor to the lower terminal block in the upper right corner.
2. Connect the zone sensor to the upper terminal block in the upper right corner.



Figure. 9 – Sensor Connectors

Connecting the refrigeration/defrost equipment

1. Connect the wires from the compressor (including the thermostat) to the correspondent terminal on the bottom side of the control (Fig. 10 for quick connect version or Fig. 11 for terminal block version).
2. Connect the defrost device (heater or hot gas solenoid) to the terminal in the control (Figs. 10 and 11).
3. Connect the wire from L1 - 120V AC or 208-240V AC line - to the terminal marked as "COM".
4. Connect also the fan wires to the terminals marked as "FAN".
5. Use the alarm connections to connect an alarm to the control, as shown in Figures 10 and 11.

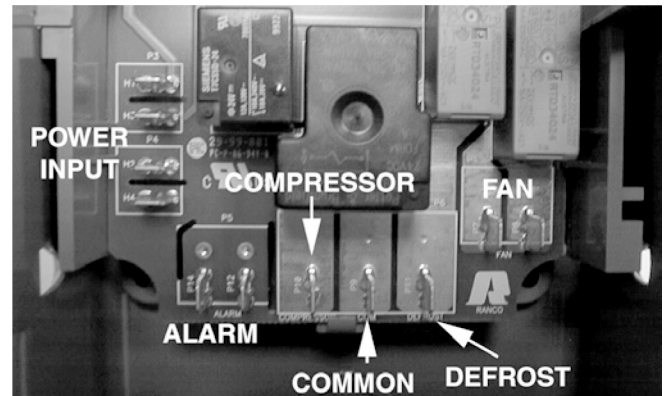

Figure. 10 – Load / AC Input Connectors – Quick Connects

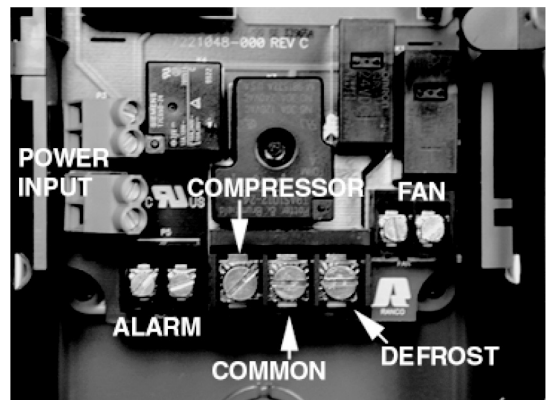

Figure. 11 – Load / AC Input Connectors – Terminal Blocks

Supplying Power to the Unit

1. The power input must be connected to the terminals on the left side of the control (Figures 10 and 11). Connect the 120V AC L1 wire (or 208-240V AC L1 wire) to the uppermost terminal and the 120V AC neutral (or 208-240V AC L2 wire) to the lowermost terminal.
2. The terminals in the middle are used to change the voltage of the unit. Refer to the wiring diagram (Figures 7 and 8) to see how to connect the jumpers for 120V AC or 208-240V AC
3. For the models supplied with a metal case, connect the ground wire to the grounding lug on the bottom of the case.

Reconnecting the Display Module

1. Reconnect the display module cable to the control.



Figure. 12 – Display Module Cable

PROGRAMING

The ERC-2 control initially powers up displaying 12:00 AM otherwise it will show the last configured selection (time or temperature). If a power outage occurs during normal operation, the control will maintain the correct time-of-day using a capacitor (batteries are not required). The time will be maintained for up to 100 hours when the capacitor is fully charged.

To initiate a **Manual Defrost**, press and hold the MAN DEF key for 3 seconds.

There are two levels of programming in the ERC-2. The first level of security will enable the user to set two parameters: Time-of-day (**CLoC**) and Setpoint temperature (**SEt**). The other level allows access to the other parameters.

Three buttons are used for the programming: SET, UP and DOWN

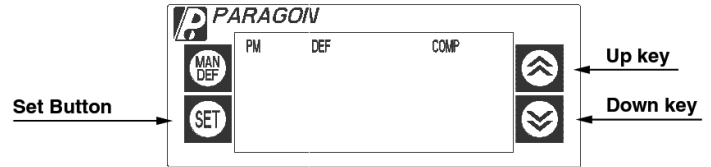

Figure. 13 – Display Layout

To change Time-Of-Day and Setpoint temperature (First Level) follow these steps:

Step 1		Press and hold set for 5 seconds. The display will show CLoC .
Step 2		Press SET again to change the time-of-day.
Step 3	or	Press UP or DOWN until the correct time-of-day is displayed.
Step 4		Press SET to accept the new time.
Step 5		Press DOWN to go to the next parameter – Setpoint Temperature - SEt (cut out).
Step 6		Press SET to change the setpoint temperature.
Step 7	or	Press UP or DOWN to go to the desired setpoint. The range is – 40° to 60°F or –40° to 16°C.
Step 8		Press SET to accept the change.
Step 9		Press DOWN to exit the first level of programming.

Note 1: During programming, if no button is pushed during 30 seconds, the control will go back to the normal operating mode. This is valid for both programming levels.

Note 2: When changing the time, press and hold the MAN DEF button for 3 seconds to change the AM/PM mode.

To change the other parameters (Second Level) follow these steps:

Step 1	or	Press and hold SET and DOWN for 10 seconds. The display will show dSPL .
Step 2		Press SET to change the parameter.
Step 3	or	Press UP or DOWN to change the options, time or temperature for the current parameter.
Step 4		Press SET to accept the new value.
Step 5		Press DOWN to go to the next parameter, then go back to Step 2. After the last parameter is displayed (ALHi), the display will go back to the normal operating condition.

Note: To scroll down the parameters without changing them, press the DOWN button.

List of Parameters

Here is a list of the parameters that can be changed in the Second Level of programming, as well as their options and ranges.

Parameter	Display Symbol	Description	Range / Options
Display Status	dSPL	Information shown on the display during operation conditions	tdAy – time-of-day rSP° – zone temperature (refrigerated space) CyCL – cycle between time and zone temperature Epr° – evaporator coil temperature
Clock Format	CLHr	Format of the time (12 or 24 hours mode)	12Hr – AM/PM format 24Hr – 24 hour format
Temperature Format	°dSP	Temperature degrees	°F – degrees Fahrenheit °C – degrees Celsius
Defrost Type	dFtP	Type of defrost used in the application	ELEC – electric heater defrost / off cycle HgAS – hot gas
Fan Status During Defrost	EFAN	Enable or not the fan during defrost	no – fan is turned off during defrost yES – fan remains on during defrost
Fan Status During Normal Mode	CFAN	Enable or not the fan during normal compressor on/off mode	on – fan is always on during normal mode CyCP – fan cycles with compressor
Defrost Interval	dFin	Type of defrost interval	TdAy – time-of-day setpoint CPrn – compressor run time tdEF – temperature initiated defrost
Minimum Compressor Off Time	CoFF	Minimum time that the compressor will remain turned off	Range: from 0 to 15 minutes
Minimum Compressor On Time	Con	Minimum time that the compressor will remain turned on	Range: from 0 to 15 minutes
Alarm Delay	ALrd	Time delay before the alarm goes off after the temperature fall off the two alarm setpoints	Range: from 0 to 59 minutes
Compressor Run Time	CPrn	Time the compressor will run between defrosts	
Number of Defrosts	nodF	Number of defrosts per day	from 0 to 8 (0 means 1 defrost every 48 hours)
Defrost Start Time	dEF1-8	Start time of each defrost	
Defrost Duration	dEFd	Defrost duration time (back-up for defrost termination temperature)	Range: from 0 minutes to 4 hours
Fan Delay	FAnd	Delay time for the fan after defrost (back-up for fan cut-in temperature)	Range: from 0 to 15 minutes
Pump Down	Pudn	Pump down duration	Range: from 0 to 59 minutes
Drip Time	driP	Drip time duration	Range: from 0 to 59 minutes
Setpoint Differential	diF°	Cut-in temperature differential Note: cut-in is cut-out plus differential	Range: from 1 to 25°
Temperature Initiated Defrost	tdEF	Temperature that will initiate a defrost cycle	Range: from –40°F to 40°F or –40°C to 4°C
Defrost Termination Temperature	dEF°	Temperature in the evaporator that will terminate the defrost cycle	Range: from 0°F to 75°F or –18°C to 24°C
Fan Cut-In Temperature	FAn°	Temperature in the evaporator that will turn the fan on after defrost	Range: from –40°F to 60°F or –40°C to 16°C
Low Temperature Alarm	ALLo	Low temperature setpoint that will make the alarm go off and the error message appear on the display	Range: from –40°F to 83°F or –40°C to 28°C
High Temperature Alarm	ALHi	High temperature setpoint that will make the alarm go off and the error message appear on the display	Range: from –40°F to 83°F or –40°C to 28°C

Important Note: To change from degrees C to F or vice versa, the user must reprogram all the parameters that are related to the temperature. The unit does not convert the parameters automatically from degrees F to C or vice versa.

Parameters (Continued)

Example 1 - To adjust the time-of-day

- Press and hold SET for 5 seconds
- Press SET again
- Press UP or DOWN until the correct time appears on the display
- Press SET to accept the new time
- Press DOWN twice to exit the programming mode

Example 2 - To set one defrost a day, at 11:59 PM

- Press and hold SET and DOWN for 10 seconds
- Press DOWN six times to go to the Defrost Interval (**dFin**)
- Press SET to change the parameter
- Press DOWN until **tdAy** appears on the display
- Press SET to accept the option
- Press DOWN eight times to go to the Number of Defrosts (**noDF**)
- Press SET to change it
- Press UP or DOWN until **1** appears on the display
- Press SET to accept the change
- Press DOWN to go to Defrost Start Time (**dEF1**)
- Press SET to change the time
- Press UP or DOWN until the **11:59** PM appears on the display
- Press SET
- Press DOWN ten times to exit the programming level

ERROR CODES

Display	Control Status
Er 1	ERC Fault – software or hardware failure
Er 2	ERC Communication Fault – indicates that there is a problem with the display module cable
Er 3	Zone Sensor Fault – indicates an open or shorted temperature sensor
Er 4	Evaporator Sensor Fault – indicates an open or shorted evaporator sensor
Er 6	Low Temperature Alarm – indicates that the temperature has dropped below the low alarm setpoint
Er 7	High Temperature Alarm – indicates that the temperature has gone above the high alarm setpoint

For Error Codes 1 and 2 cut the power to the unit and correct the problem to reset the display.

For Codes 3 and 4, press the UP or DOWN button on the display to reset the error message. If the display still shows the message, the sensor must be replaced.

The Error Codes 6 and 7 will be automatically reset once the temperature is back within the two setpoints.

TECHNICAL SPECIFICATIONS

Input Power: 120/208-240V AC 50/60 Hz (+10, -15%)

Power Consumption: 5VA @ 120/240V AC

Zone and Evaporator Coil Temperature Sensors:
NTC thermistor. Range – 40°F to 199°F

Ambient Operating Conditions:
– 40°F to 122°F; 0 to 95% RH (non-condensing)

Display Module Dimensions: 2.75”W x 1.10”H x 1.38”D

Case Dimensions: 4.40”W x 7.82”H x 3.80”D

Shipping Weight: 3.0 lbs.

Agency Approvals:

c-UR-us Recognized Component – Models ERC2-1xxxxx & ERC2-3xxxxx
c-UL-us Listed Product – Models ERC2-2xxxxx & ERC2-4xxxxx
NSF International Certified – Models ERC2-1xxxxx & ERC2-2xxxxx

Output Relay Ratings:

Compressor: SPST NO

	120V AC	208V AC	240V AC
Horsepower Rating (HP)	1	1.5	2
FLA / LRA	16 / 96	12 / 72	12 / 72
Pilot Duty	470	470	470

Defrost: SPST NO

	120V AC	208V AC	240V AC
Resistive Amps	16	16	16
Horsepower Rating (HP)	1/2	3/4	1
Pilot Duty (VA)	470	470	470

Evaporator fan: SPST NO

	120V AC	208V AC	240V AC
Resistive Amps	16	16	16
Horsepower Rating (HP)	1/2	3/4	1
FLA / LRA	10 / 59	8 / 48	8 / 48
Pilot Duty (VA)	470	470	470

Alarm: SPST NO

	120V AC	208V AC	240V AC
Resistive Amps	5	5	5
Pilot Duty (VA)	240	240	240



Customer Service Telephone 1.800.304.6563
Customer Service Facsimile 1.800.426.0804
HVACCustomerService@robertshaw.com

For Technical Service
Telephone 1.800.445.8299
TechnicalService@robertshaw.com

Robertshaw®, Ranco®, Paragon® and Uni-Line® are trademarks of Robertshaw its subsidiaries and/or affiliated companies. All other brands mentioned may be the trademarks of their respective owners.

www.uni-line.com
www.robertshaw.com
©2015 Robertshaw
10/15 –7515010 Rev E